

NFB™ Rack outboard steering

The easy-to-sell, easy-to-install upgrade to the most popular Rack and Pinion steering system in boating. Teleflex has applied its patented No FeedBack technology to the incredible precision of a rack and pinion system, and engineered-in serious advances in steering comfort and control. The NFB Rack is the rack and pinion steering system of tomorrow, and it's available today in single cable configuration for outboards up to V-6.



Features:

- Patented No FeedBack™ Steering mechanism.
- Precise feel of 4 turns from lock-to-lock.
- Minimal clutch free play.
- Standard 3/4" tapered steering shaft.
- Stainless steel cable output ends.
- Fast, easy installation; back mount design allows quick placement in dash *PLUS* mounting hardware fits industry-standard Teleflex and Morse rack holes.
- Meets A.B.Y.C. standards.
- Meets N.M.M.A. certification requirements.

Applications:

NFB Rack is suitable for most boats with single non-power assisted outboard engines up to V-6 and minimal engine flutter or steering instability.

New Back Mount design means easy installation; helm & cable are installed as a unit from behind dash and replace standard Teleflex rack steering without dash modifications.

For single station use only.

****Replaces most MORSE CONTROLS and older TELEFLEX rack and pinion steering systems for non-power-assist outboards & I/Os.**

NFB™ RACK
SINGLE CABLE SYSTEM

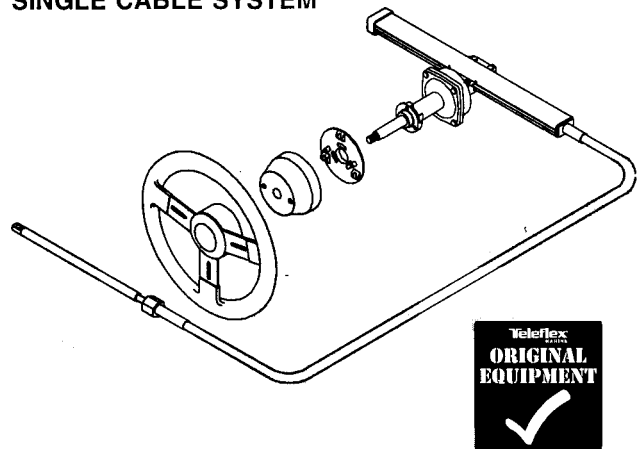

(4 turns lock-to-lock)

Tilt
STEERING
available!

NFB™ Rack outboard steering

Complete System:

NFB Rack Steering Kit
(Single Cable) SS151XX

Components:

NFB Rack Helm (single/dual) SH5230P

Rack Single Cable SSC134XX
(XX = cable length in feet. A 14' SSC134 would be SSC13414.)

Rack NFB Bezel (90°) SB39544P

Options:

NFB Rack Tilt Dash Module SH1535230
Includes tilt helm and mechanism. Easy way to upgrade to Tilt or replace older Tilt systems. Requires SSC134 cable.

NFB Rack Tilt Helm (single/dual) ... SH91630P*
** Requires SH91500/SH91700 tilt mechanism to complete Tilt Steering system installation.*

Performance Tilt Mechanism SH91500P
TFXtreme Tilt Mechanism SH91700P

Dash Wedge Kit (10°) SB27448P
Dash Wedge Kit (20°) SB27449P

TFXTREME Rack Single Cable SSC154XX
Use this cable for minimal backlash & superior steering response. (XX = cable length in feet. A 14' SSC134 would be SSC15414.)

Universal Tie Bar SA27252P
(NOTE: Maximum tie bar length: 25-1/2")

Cable Gard (fits most tilt tubes) SA39329P

Service Items:

Steering Wheel Hardware Kit 2745417P

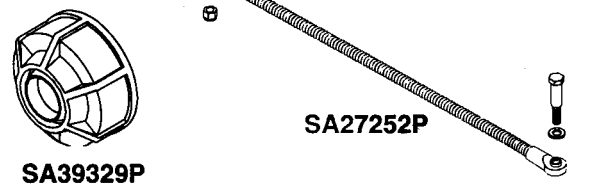
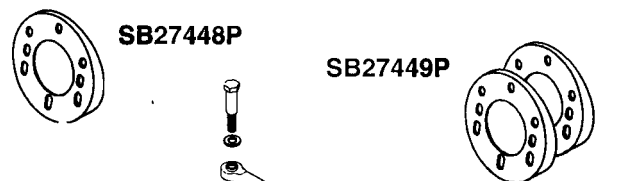
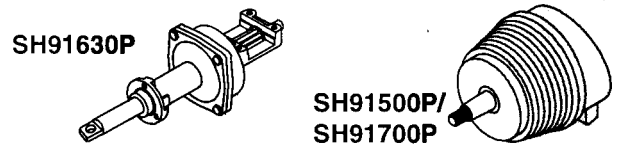
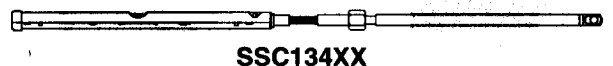
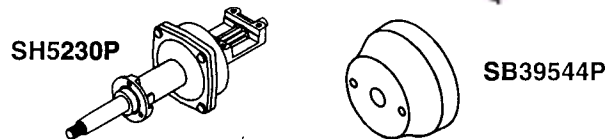

NOTE: Teleflex rack cables SSC134XX, SSC135XX and SSC154XX DO NOT replace the SSC124XX or any Morse Rack & Pinion cables and can only be used with current generation Teleflex Rack & Pinion helms.

The Rack sterndrive steering

Traditional Teleflex mechanical steering is still the choice for stern drives, inboards and other power assisted applications. It's just right for power steered boats in which No FeedBack™ systems are not required. Our new Rack features the precision and comfort of four turns lock-to-lock. In single cable configurations, this is the best 4-turn choice for power-steered boats.

Features:

- Precise, easy 4 turns lock-to-lock.
- Kits include: cable, helm, bezel and hardware.
- Standard 3/4" tapered steering shaft.
- Stainless steel cable output ends.
- Fast, easy installation: back mount design allows quick placement in dash *PLUS* mounting hardware fits industry-standard Teleflex and Morse rack holes.
- Meets A.B.Y.C. standards.
- Meets N.M.M.A. certification requirements.

Applications:

Virtually all power-assisted stern drive boats with wheels up to 16" diameter.

Back Mount Rack Replaces 1984-date Teleflex "The Rack" steering without dash modification. (Requires use of SSC134 Back Mount Rack cable.)

For single station use only.

**** Replaces most MORSE CONTROLS and older TELEFLEX rack and pinion steering systems for power-assist outboards, I/Os and small inboards.**

Teleflex
MARINE

THE RACK SINGLE CABLE SYSTEM

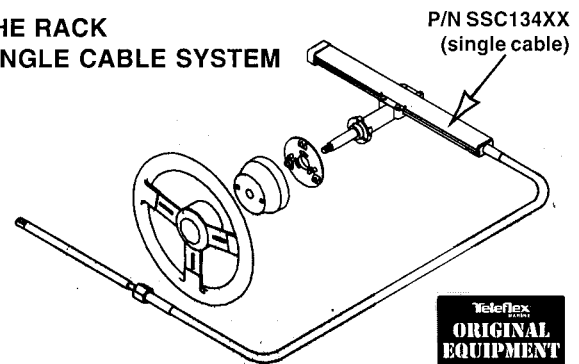

P/N SSC134XX
(single cable)



THE RACK TWIN CABLE SYSTEM

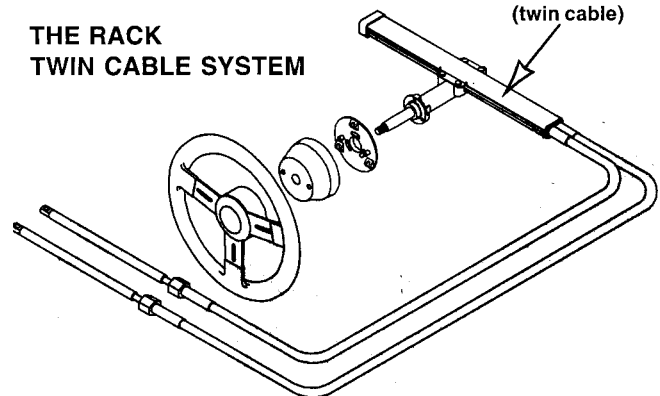

P/N SSC135XX
(twin cable)

(4 turns lock-to-lock)

Tilt
STEERING
available!

Phone: 800-225-0004 ☎ Fax: 908-486-1056
e-mail: sales@sealandpower.com

The Rack sterndrive steering

Complete System:

BM Rack Steering Kit
(single cable) SS141XX

Components:

Back Mount Rack Helm (single/dual) SH5210P

Back Mount Rack Single Cable SSC134XX
(XX = cable length in feet. A 14' SSC134 would be SSC13414.)

Back Mount Bezel (90°) SB39526P

Options:

BM Rack Tilt Dash Module SH1535210
Includes tilt helm and mechanism. Easy way to upgrade to Tilt or replace older Tilt systems. Requires SSC134 or SSC135 cable.

BM Rack Tilt Helm (single/dual) SH91610P*
** Requires SH91500/SH91700 tilt mechanism to complete Tilt Steering system installation.*

Performance Tilt Mechanism SH91500P
TFXtreme Tilt Mechanism SH91700P

TFXTREME Rack Single Cable SSC154XX
Use this cable for minimal backlash & superior steering response. (XX = cable length in feet. A 14' SSC134 would be SSC15414.)

Back Mount Rack Dual Cable SSC135XX†
† For dual rack & pinion steered stern drives.

Dash Wedge Kit (10°) SB27448P
Dash Wedge Kit (20°) SB27449P

Back Mount Rack Friction Device 3953114P

Cable Gard (fits most tilt tubes) SA39329P

Service Items:

Old Style "The Rack" Cable
(1984-date) SSC124XX**

** For 1984-1996 "Old Style" The Rack rack & pinion systems. Does not fit "New Style" ("Back Mount") rack systems and is not interchangeable with SSC134.

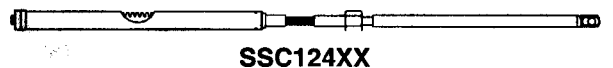
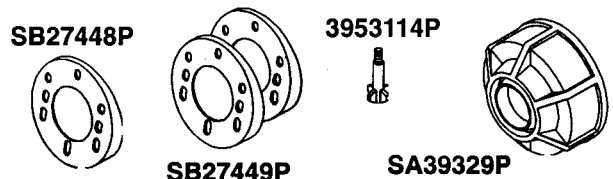
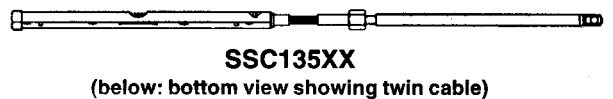
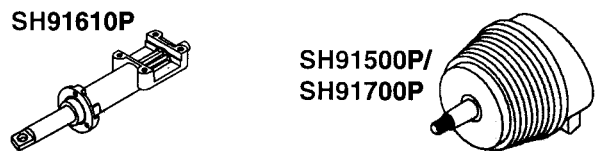
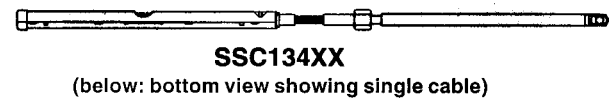
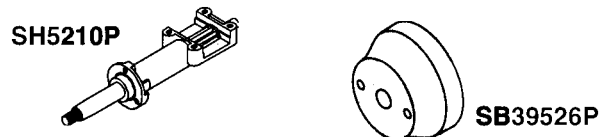

NOTE: Teleflex rack cables SSC134XX, SSC135XX and SSC154XX DO NOT replace the SSC124XX or any Morse Rack & Pinion cables and can only be used with current generation Teleflex Rack & Pinion helms.