

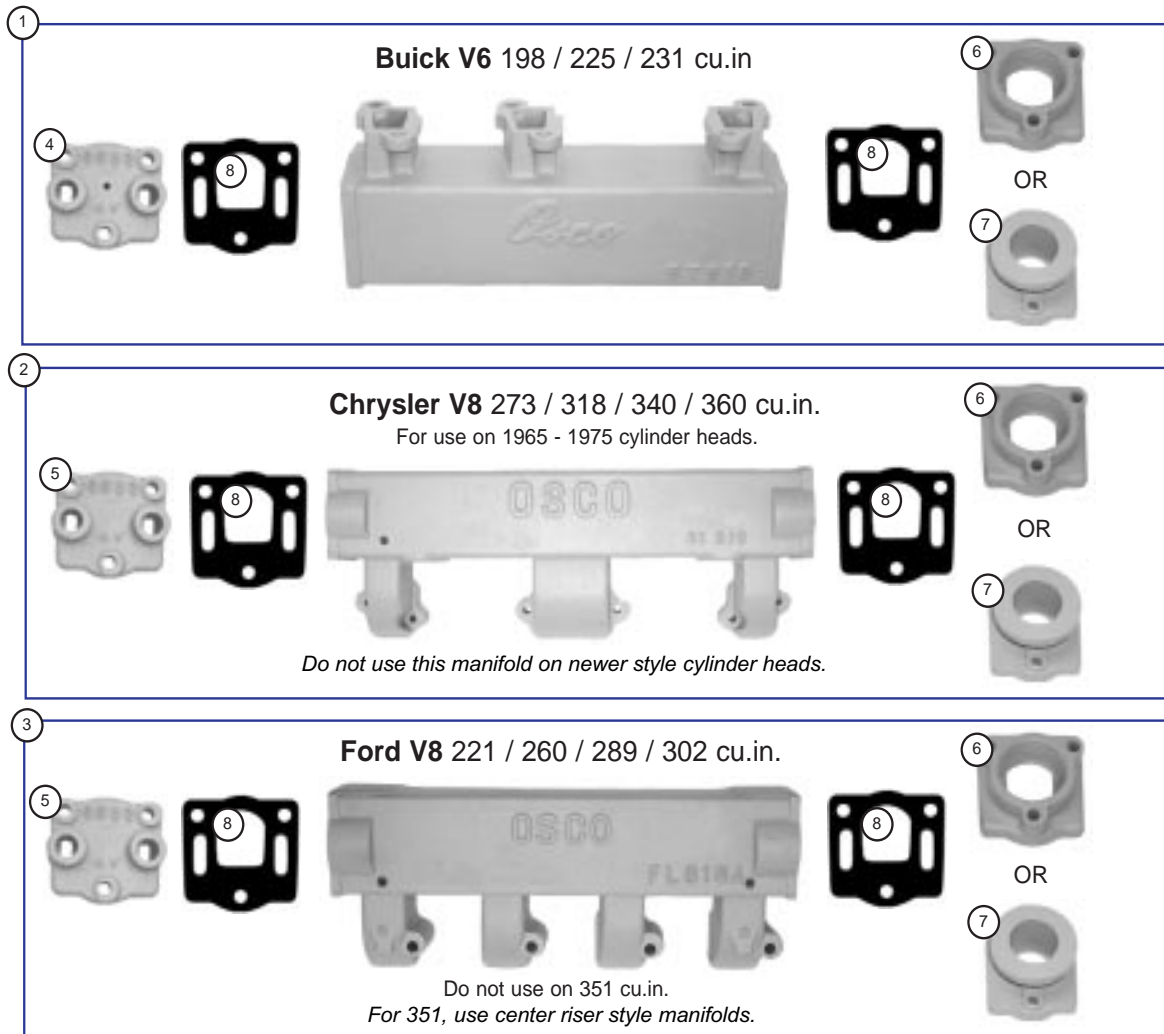

Conversion Manifolds: "A" Style

OSCO

Necessary pipe plugs are included.



1. **BT618xAE** **Manifold Assembly.** Fits Buick V6 198 / 225 / 231 cu.in. engines. Includes end plates AW-CH and AE, (2) AG gaskets, end plate and manifold mounting hardware.
1. **BT618xRA** **Manifold Assembly.** Fits Buick V6 198 / 225 / 231 cu.in. engines. Includes end plates AW-CH and RA, (2) AG gaskets, end plate and manifold mounting hardware.
2. **CI818xAE** **Manifold Assembly.** Fits Chrysler V8 273 / 318 / 340 / 360 cu.in. engines. Includes end plates AW and AE, (2) AG gaskets, end plate and manifold mounting hardware.
2. **CI818xRA** **Manifold Assembly.** Fits Chrysler V8 273 / 318 / 340 / 360 cu.in. engines. Includes end plates AW and RA, (2) AG gaskets, end plate and manifold mounting hardware.
3. **FL818xAE** **Manifold Assembly.** Fits Ford V8 221 / 260 / 289 / 302 cu.in. engines. Includes end plates AW and AE, (2) AG gaskets, end plate and manifold mounting hardware.
3. **FL818xRA** **Manifold Assembly.** Fits Ford V8 221 / 260 / 289 / 302 cu.in. engines. Includes end plates AW and RA, (2) AG gaskets, end plate and manifold mounting hardware.
4. **AW-CH** **Front Plate,** with choke tube hole. Included with BT618 manifold assembly. For 1/2" pipe fittings.
5. **AW** **Front Plate.** Included with FL818 manifold assembly. For 1/2" pipe fittings.
6. **AE** **End Plate,** 2" threaded. Used to adapt the "A" style manifolds to the 18000 series elbows.
7. **RA** **End Plate,** circular flange. Used to adapt the "A" style manifolds to the 1800 series risers and elbows.
8. **AG** **Gasket,** end plate. Fits both ends of the "A" style manifolds.



Conversion Manifolds: "B" Style

OSCO

Necessary pipe plugs are included.



1. **CV818-350xBE** **Manifold Assembly.** Fits Chevy V8 283 / 305 / 307 /327 / 350 / 400 cu.in. engines. Includes end plates BW and BE, (2) BG gaskets, end plate and manifold mounting hardware.
1. **CV818-350xRB** **Manifold Assembly.** Fits Chevy V8 283 / 305 / 307 /327 / 350 / 400 cu.in. engines. Includes end plates BW and RB, (2) BG gaskets, end plate and manifold mounting hardware.
2. **CW818xBE** **Manifold Assembly.** Fits Chevy V8 348 / 409 cu.in. engines. Includes end plates BW and BE, (2) BG gaskets, end plate and manifold mounting hardware.
2. **CW818xRB** **Manifold Assembly.** Fits Chevy V8 348 / 409 cu.in. engines. Includes end plates BW and RB, (2) BG gaskets, end plate and manifold mounting hardware.
3. **CW818-396xBE** **Manifold Assembly.** Fits Chevy V8 396 / 401cu.in. engines. Includes end plates BW and BE, (2) BG gaskets, end plate and manifold mounting hardware.
3. **CW818-396xRB** **Manifold Assembly.** Fits Chevy V8 396 / 401cu.in. engines. Includes end plates BW and RB, (2) BG gaskets, end plate and manifold mounting hardware.
4. **BW** **Front Plate,** for 1/2" pipe fittings. Fits "B" style manifolds.
5. **BE** **End Plate,** 2 1/2" threaded. Used to adapt the "B" style manifolds to the 18000 series elbows.
6. **RB** **End Plate,** circular flange. Used to adapt the "B" style manifolds to the 1800 series risers and elbows.
7. **BG** **Gasket,** end plate. Fits both ends of the "B" style manifolds.



Conversion Manifolds: "B" Style

Necessary pipe plugs are included.

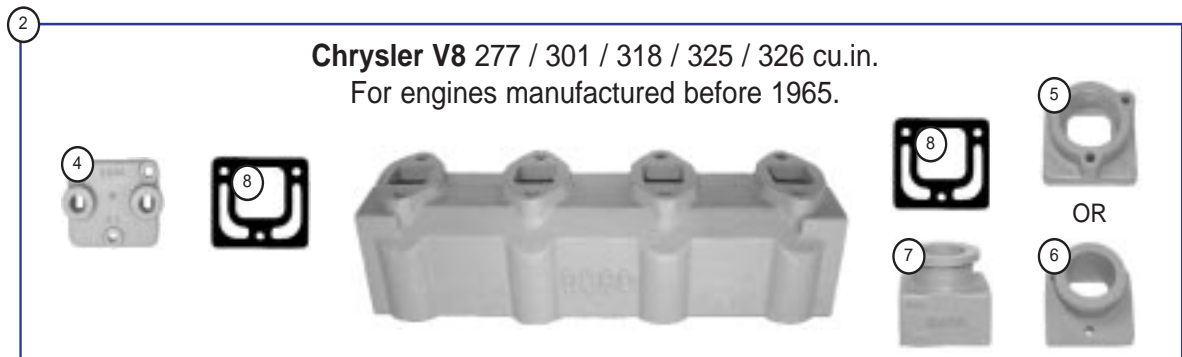

- 1. **CH618xBE** **Manifold Assembly.** Fits Chrysler Slant 6 170 / 198 / 225 cu.in. engines. Includes end plates BW and BE, (2) BG gaskets, end plate and manifold mounting hardware.
- 1. **CH618xRB** **Manifold Assembly.** Fits Chrysler Slant 6 170 / 198 / 225 cu.in. engines. Includes end plates BW and RB, (2) BG gaskets, end plate and manifold mounting hardware.
- 2. **CI818-56xBE** **Manifold Assembly.** Fits Chrysler V8 277 / 301 / 318 / 325 / 326 cu.in. engines. Includes end plates BW and BE, (2) BG gaskets, end plate and manifold mounting hardware.
- 2. **CI818-56xRB** **Manifold Assembly.** Fits Chrysler V8 277 / 301 / 318 / 325 / 326 cu.in. engines. Includes end plates BW and RB, (2) BG gaskets, end plate and manifold mounting hardware.
- 2. **CI818-56xRBE** **Manifold Assembly.** Fits Chrysler V8 277 / 301 / 318 / 325 / 326 cu.in. engines. Includes end plates BW and RBE, (2) BG gaskets, end plate and manifold mounting hardware. For port side only.
- 3. **BWF-CS** **Front Plate.** Fits CH618. Has counter-sunk holes.
- 4. **BW** **Front Plate,** for 1/2" pipe fittings. Fits "B" style manifolds.
- 5. **BE** **End Plate,** 2 1/2" threaded. Used to adapt the "B" style manifolds to the 18000 series elbows.
- 6. **RB** **End Plate,** circular flange. Used to adapt the "B" style manifolds to the 1800 series risers and elbows.
- 7. **RBE** **End Plate,** 1 3/4" extended circular flange. Use in place of end plate RB on port side only on CI818-56.
- 8. **BG** **Gasket,** end plate. Fits both ends of the "B" style manifolds.

Phone: 800-225-0004 ☎ **Fax: 908-486-1056**
e-mail: sales@sealandpower.com



Conversion Manifolds: "B" Style

OSCO

Necessary pipe plugs are included.

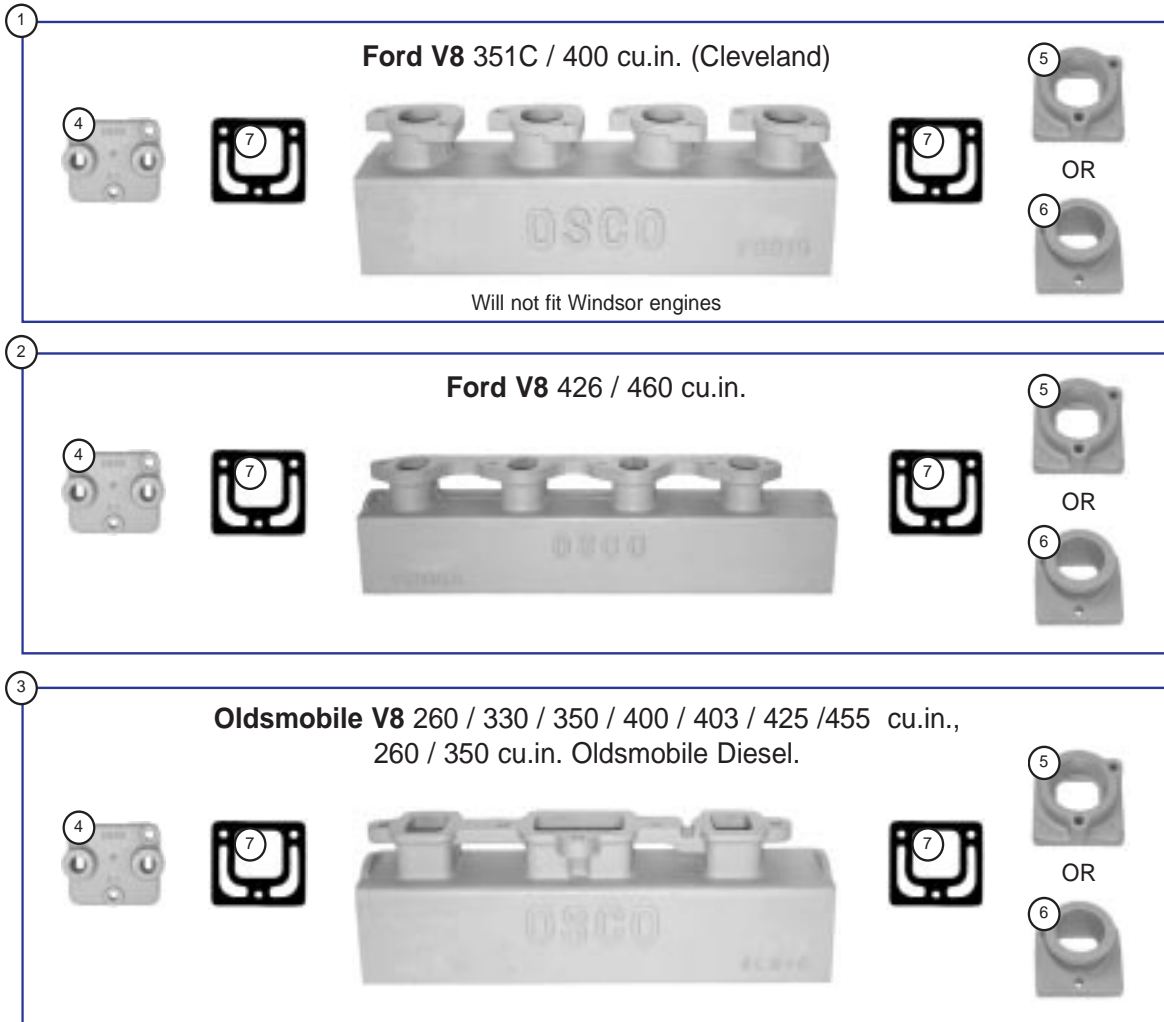

- 1. **FB818xBE** **Manifold Assembly.** Fits Ford V8 351C / 400 cu.in. Cleveland engines. Includes end plates BW and BE, (2) BG gaskets, end plate and manifold mounting hardware.
- 1. **FB818xRB** **Manifold Assembly.** Fits Ford V8 351C / 400 cu.in. Cleveland engines. Includes end plates BW and RB, (2) BG gaskets, end plate and manifold mounting hardware.
- 2. **FH818xBE** **Manifold Assembly.** Fits Ford V8 426 / 460 cu.in. engines. Includes end plates BW and BE, (2) BG gaskets, end plate and manifold mounting hardware.
- 2. **FH818xRB** **Manifold Assembly.** Fits Ford V8 426 / 460 cu.in. engines. Includes end plates BW and RB, (2) BG gaskets, end plate and manifold mounting hardware.
- 3. **OL818xBE** **Manifold Assembly.** Fits Oldsmobile V8 260 / 330 / 350 / 400 / 403 / 425 / 455 cu.in. engines. Includes end plates BW and BE, (2) BG gaskets, end plate and manifold mounting hardware.
- 3. **OL818xRB** **Manifold Assembly.** Fits Oldsmobile V8 260 / 330 / 350 / 400 / 403 / 425 / 455 cu.in. engines. Includes end plates BW and RB, (2) BG gaskets, end plate and manifold mounting hardware.
- 4. **BW** **Front Plate,** for 1/2" pipe fittings. Fits "B" style manifolds.
- 5. **BE** **End Plate,** 2 1/2" threaded. Used to adapt the "B" style manifolds to the 18000 series elbows.
- 6. **RB** **End Plate,** circular flange. Used to adapt the "B" style manifolds to the 1800 series risers and elbows.
- 7. **BG** **Gasket,** end plate. Fits both ends of the "B" style manifolds.



Conversion Manifolds: Diesel Engines

OSCO

Necessary pipe plugs are included.

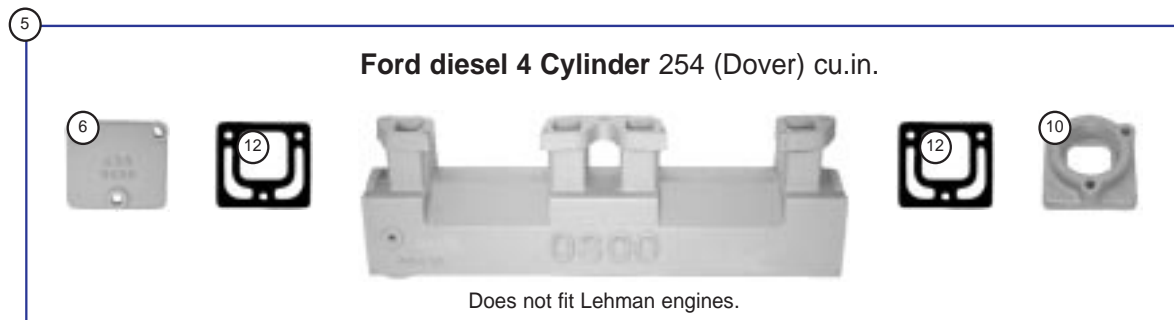
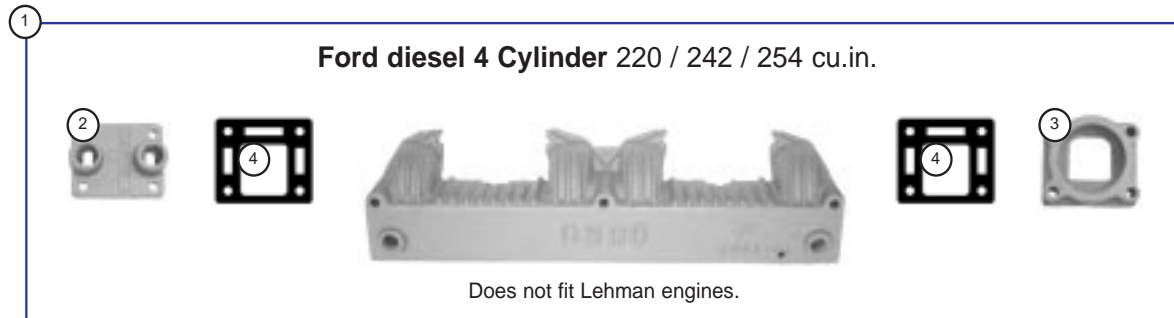

1. **4DF418A** **Manifold Assembly.** Fits Ford diesel 4 Cylinder 220 / 242 / 254 cu.in. engine. Includes end plates 4DFE and JAW, (2) 4DF-G gaskets and end plate mounting hardware.
2. **JAW** **Front Plate,** for 1/2" pipe fittings. Fits 4DF418A manifold.
3. **4DFE** **End Plate,** 2" threaded. Used to adapt the 4DF418A manifold to the 18000 series elbows.
4. **4DF-G** **Gasket,** end plate. Fits both ends of the 4DF418A manifold.
5. **DD418** **Manifold Assembly.** Fits Ford diesel 4 Cylinder 254 (Dover) cu.in. engine. Includes end plates BWF and BE, (2) AG gaskets and end plate mounting hardware.
6. **BWF** **End Plate,** block off.
7. **CD818xBE** **Manifold Assembly.** Fits GM diesel V8 6.2 / 6.5 Liter engines. Includes end plates BW and BE, (2) BG gaskets and end plate mounting hardware.
7. **CD818xB** **Manifold Assembly.** Fits GM diesel V8 6.2 / 6.5 Liter engines. Includes end plates BW and RB, (2) BG gaskets and end plate mounting hardware.
8. **CDSN** **Mounting Stud and nut,** for CD818 manifold. Sold individually. (8) required per manifold.
9. **BW** **Front Plate,** for 1/2" pipe fittings.
10. **BE** **End Plate,** 2 1/2" threaded. Used to adapt the "B" style manifolds to the 18000 series elbows.
11. **RB** **End Plate,** circular flange. Used to adapt the "B" style manifolds to the 1800 series risers and elbows.
12. **BG** **Gasket,** end plate. Fits both ends of the "B" style manifolds.