



Generic Replacements for:

MERCURISER

**GM In-Line Six Cylinder
250 cu.in.**

Model 160
Using Mercruiser riser #'s 39920 or 55538

**DO NOT USE THIS MANIFOLD IN
CLOSED COOLING APPLICATIONS.**

Necessary pipe plugs are included.

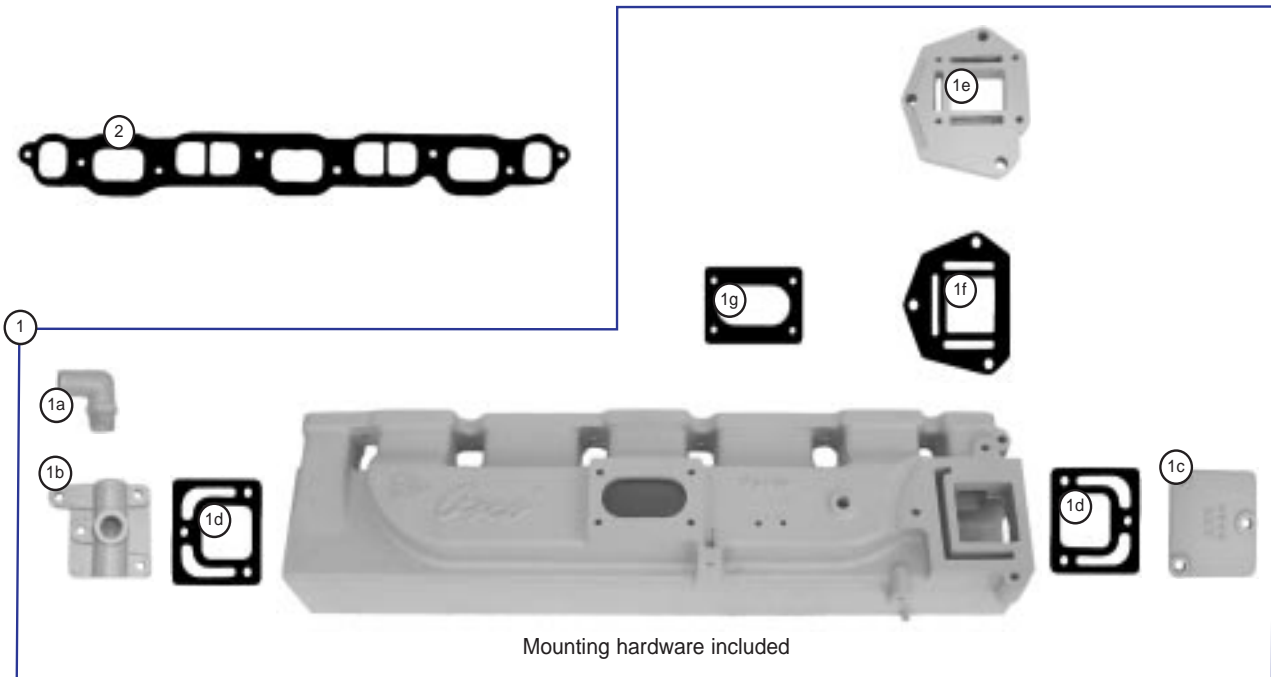
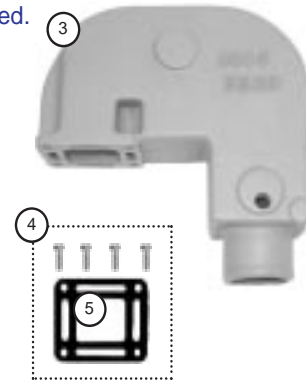

- 1. **MO618-55*** **Manifold Assembly.** Fits 250 cu.in. GM in-line six cylinder engines equipped with Mercruiser riser #'s 39920 or 55538. Includes items 1a through 1g and mounting hardware. Does not include manifold to cylinder head gasket.
- 1a. **F68N9 *** **Water Fitting,** plastic 90°. 3/4" MPT x 1" hose barb.
- 1b. **BWS *** **Front Plate.** Fits MO618 series manifolds.
- 1c. **BWF *** **Rear Plate.** Fits MO618 series manifolds.
- 1d. **BG *** **Gasket,** end plate. Fits BWS and BWF and plates.
- 1e. **MO65538 *** **Riser Adapter.** Adapts 5538 riser to manifold.
- 1f. **MO618-G *** **Gasket,** riser adapter to manifold.
- 1g. **CY-MG*** **Gasket** for 2 barrel Rochester carburetor, studs measure, 3/4" x 1 1/8" on center.
- 2. **CY6-GH** **Gasket,** manifold to engine cylinder head. Replaces Mercruiser # 27-46401.
- 3. **5538** **Riser,** 2 1/2" exhaust outlet, 90° down angle. Replaces Mercruiser #'s 39920 and 55538. Use mounting kit 5538-MK.
- 4. **5538-MK** **Mounting Kit,** riser. Fits 5538 riser. Includes 5538-G gasket and mounting hardware.
- 5. **5538-G** **Gasket,** riser. Included in 5538-MK mounting kit.

* Item #'s 1a through 1g are included with the manifold assembly.



Generic Replacements for:

MERCURISER

GM In-Line Six Cylinder
250 cu.in.
Model 165
Equipped with Mercruiser riser
#s 76351, 76325, 60426,
49964, 76771 or 60427

**DO NOT USE THIS MANIFOLD IN
CLOSED COOLING APPLICATIONS.**

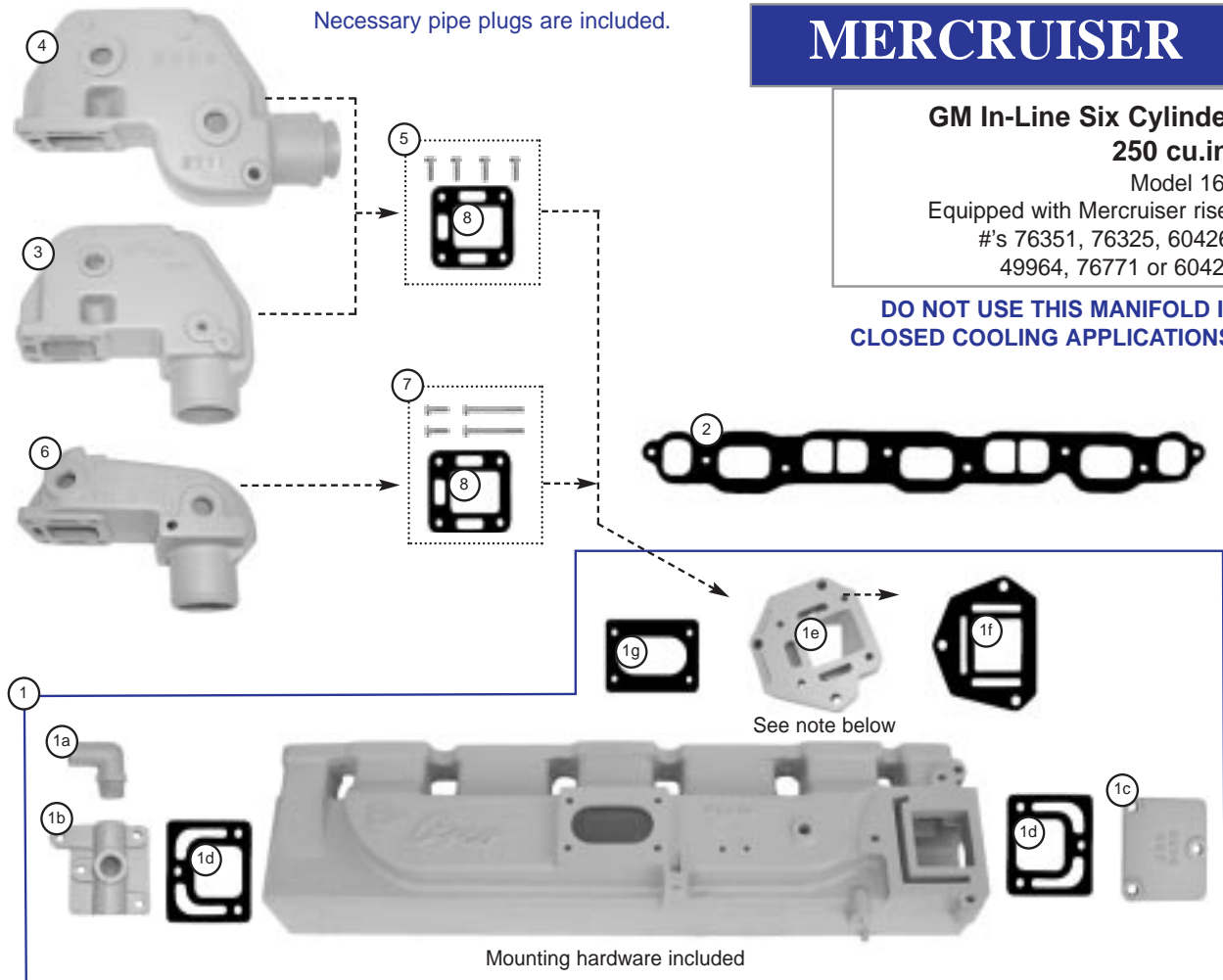

1. **MO618-63*** **Manifold Assembly.** Fits 250 cu.in. GM in-line six cylinder engines equipped with Mercruiser riser #'s 76351, 76325, 60426, 49964, 76771 or 60427. Includes items 1a through 1g and mounting hardware. Does not include manifold to cylinder head gasket.
- 1a. **F68N9 *** **Water Fitting,** plastic 90°. 3/4" MPT x 1" hose barb.
- 1b. **BWS *** **Front Plate.** Fits MO618 series manifolds.
- 1c. **BWF *** **Rear Plate.** Fits MO618 series manifolds.
- 1d. **BG *** **Gasket,** end plate. Fits BWS and BWF and plates.
- 1e. **MO66351 *** **Riser Adapter.** Adapts 6325, 6351, and 6771 risers to manifold. **See note below.**
- 1f. **MO618-G *** **Gasket,** riser adapter to manifold.
- 1g. **CY-MG*** **Gasket,** for 2 barrel Rochester carburetor. Studs measure 3 3/4" x 1 7/8" on centers.
2. **CY6-GH** **Gasket,** manifold to engine cylinder head. Replaces Mercruiser # 27-46401.
3. **6351** **Riser,** 3" exhaust outlet, 90° down angle. For use in most inboard/outboard applications. Replaces Mercruiser #'s 76351, 60426 and 49964. Use mounting kit 6371-MK.
4. **6771** **Riser,** 3" exhaust outlet, 0° down angle. For use in most inboard applications. Replaces Mercruiser #'s 76771 and 60427. Use mounting kit 6371-MK.
5. **6371-MK** **Mounting Kit,** riser. Fits 6351 and 6771 risers. Includes 52076 gasket and mounting hardware.
6. **6325** **Riser,** low profile, 3" exhaust outlet, 90° down angle. For use in inboard/outboard applications where height is a problem. Replaces Mercruiser # 76325. Use mounting kit # 6325-MK.
7. **6325-MK** **Mounting Kit,** riser. Fits 6325 riser. Includes 52076 gasket and mounting hardware.
8. **52076** **Gasket,** riser. Included in 6371-MK and 6325-MK mounting kits.

* Item #'s 1a through 1g are included with the manifold assembly.

Note: Riser mounts at slight angle to compensate for wider manifold design.



Generic Replacements for:

OMC

**GM In-Line Six Cylinder
250 cu.in.**

Model 160, using OMC riser
#'s 980020 or 980188.

**DO NOT USE THIS MANIFOLD IN
CLOSED COOLING APPLICATIONS.**

Necessary pipe plugs are included.

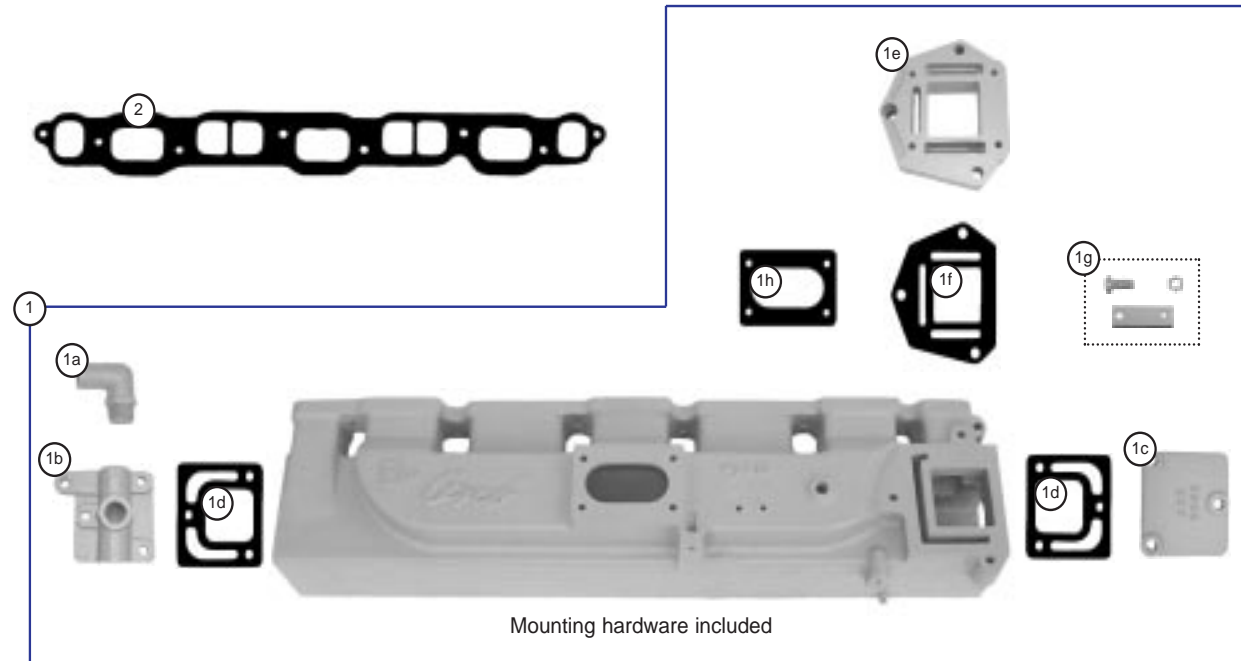
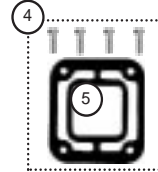

- 1. **MO618-01*** **Manifold Assembly.** Fits 250 cu.in. GM in-line six cylinder engines equipped with OMC riser #'s 980020 or 980188. For use with the 0188 riser. Includes items 1a through 1h and mounting hardware. Does not include manifold to cylinder head gasket.
- 1a. **F68N9*** **Water Fitting,** plastic 90°, 3/4" MPT x 1" hose barb.
- 1b. **BWS*** **Front Plate,** for MO618 series manifolds.
- 1c. **BWF*** **Rear Plate,** for MO618 series manifolds.
- 1d. **BG*** **Gasket,** fits both end plates.
- 1e. **MO60188*** **Riser Adapter,** adapts 0188 riser to manifold.
- 1f. **MO618-G*** **Gasket,** riser adapter to manifold.
- 1g. **MO601*** **Throttle Linkage Adapter,** to be used with existing OMC carburetor linkage. Included with MO618-01.
- 1h. **CY-MG*** **Gasket** for 2 barrel Rochester carburetor, studs measure, 3 1/4" x 1 7/8" on center. Included with MO618-01.
- 2. **CY6-GH** **Gasket,** manifold to engine cylinder head. Replaces OMC # 907932.
- 3. **0188** **Riser,** 3 3/8" outlet, 90° down angle. Replaces OMC #'s 980020 and 980188. Use mounting kit # 0188-MK.
- 4. **0188-MK** **Mounting Kit,** fits riser 0188. Includes 0188-G gasket and mounting hardware to bolt riser to adapter.
- 5. **0188-G** **Gasket,** riser. Included in 0188-MK mounting kit. Replaces OMC # 908013.

* Item #'s 1a through 1h are included with the manifold assembly.