

## Pneumatic Valve Controls

The Teleflex Morse compensating air valve controls direct the modular actuation of pneumatic directional control valves on industrial equipment and mobile vehicles. Each air valve controls one directional control valve spool. In operation, each air valve balances the output pressure against an internal spring that is loaded by a plunger attached to the operating lever. Therefore, the output or working pressure is directly related to the lever position. When the lever is released, the output pressure is discharged through the exhaust port.

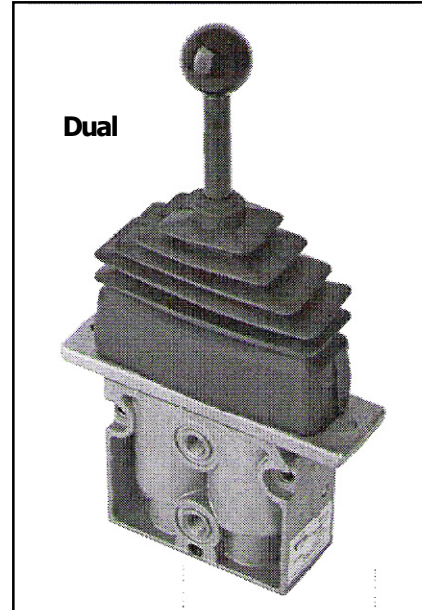
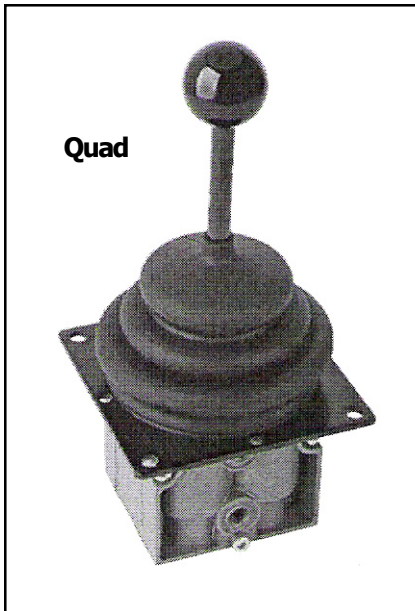

### Key Features

- Precise Control - the Teleflex Morse design allows for feathering of the valves, providing precise control of the system.
- Multiple Controls - the dual valve controls can be banked in instrument consoles to control multiple valves. Assemblies with spacer blocks and bent handles are available to make operation easier with or without gloves.
- Detented Units - these units are similar to standard dual controllers but also have a neutral detent mechanism. To shift these controllers, the handle lock must be raised to allow the handle to be shifted from the neutral to a work position.

### Operation

In operation, each air valve balances the output pressure against an internal spring that is loaded by a plunger attached to the operating lever. Therefore, the output or working pressure is directly related to the lever position. The further the lever is moved toward the full shift position, the higher the output pressure becomes. When the lever is released, the output pressure is discharged through the exhaust port.

## Pneumatic Valve Controls

Technical Specifications:	
Port Size	1/8" -27 NPT
Maximum Operating Pressure With clean, dry air	142 psi
Operating Temperature	-40° to 212° F
Flow Rating	11.7 cfm @ 100 psi
Mounting	Panel Mounting
Mounting Attitude	Optional
<b>Materials</b>	
Poppets	Brass
Housing	Nylon
Body	Aluminum
Lever	Steel
Seals	Viton, Nitril
Weight (dual valve)	Approx. 1 lb. 4 oz.

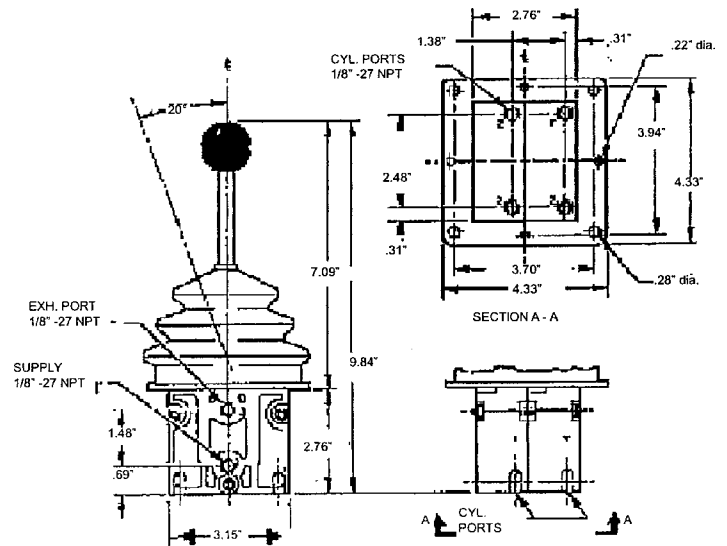

### Ordering Information:

Pneumatic Valve Controls	Part Number
Dual Valve Control (does not include handle)	866000
Dual Valve Control, with Joystick Handle	866250
Dual Valve Control, One Detent/Off Center	866500
Dual Valve Control, Two Detents/Center & Off Center	866510
Dual Valve Control, Two Detents/Off Center	866520
Dual Valve Control, Neutral Detent	866530
Dual Valve Control, Three Detent Positions	866540

Handles	Part Number
Handle Assy., Straight	858103
Handle Assy., 20 Degree	858109
Handle Assy., 35 Degree	858114
Handle Assy., 45 Degree	858119
Handle Assy., 55 Degree	858124
Quad Valve Control, w/Joystick Handle	866800
Spacer Block - 2 inch	866651

Installation Kits	Part Number
Single Dual Valve Mounting Kit	866900-K1000
Twin Dual Valve Mounting Kit with Bent Levers	866900-K2000
Triple Dual Valves Mounting Kit with Bent Levers, Twin Dual Valves with Spacer and Vertical Handles or Dual Valves with Detents	866900-K3000
Four Dual Valves Mounting Kit with Bent Levers, Triple Dual Valves with Vertical Handles and Multiple Spacers or Dual Valves with Detents	866900-K4000
Five Dual Valves Mounting Kit with Bent Levers, Four Dual Valves with Vertical Handles and Multiple Spacers or Dual Valves with Detents	866900-K5000